

Ultra Arc Series II Short Throw Followspot



FEATURES

- throws from 25-150 feet
- 3:1 zoom range
- draws less than 8 amps
- 250 hour lamp life
- douser, iris and clipper
- built-in, six-color automatic color changer
- steep 70° downward tilt and 60° upward tilt
- full 360° horizontal sweep
- superb lumen maintenance
- hour meter
- lightweight aluminum housing, bulkheads and components
- built-in solid-state ballast
- sturdy 4-point collapsible base
- quiet and cool running
- easy to transport – easy to operate – easy to afford

OPTIONS

Custom Road Case rugged, fiberglass coated, lightweight; designed specifically for the Ultra Arc Series II.

Available for 220/240 volt 50 Hz operation.

DESCRIPTION

The **Ultra Arc Series II** followspot from Strong Lighting continues the Ultra Arc tradition of state-of-the art lighting bringing a standard of efficiency and operational simplicity to the entertainment industry.

The Series II features the bright and efficient Osram HTI lamp comprised of a compact source metal halide arc tube computer positioned for maximum output and field flatness in a high quality specially designed dichroic reflector. The HTI lamp has a rated life of 250 hours and a constant color temperature of 5600° Kelvin.

Designed for throws from 25 feet to 150 feet the Series II lens system is designed to optimize lamp output. The combination of coated optics and a precision relay lens system makes the Series II a competitor with other followspots using 1000W – 2000W discharge lamps. The solid-state electronic ballast draws less than 8 amps and operates on standard 120 volt 50/60 Hz AC power.

Options include custom road case and 220/240 50Hz volt operation.

Affordability, quality construction and ease of handling insure that the Ultra Arc line of followspots will cover any application from the smallest schools, clubs and churches to full-scale entertainment facilities.

ULTRA
ARC **II**

Strong
Lighting

10533 Chandler Rd, Suite 101
La Visa, NE 68128
Tel. 402-506-9096
www.strong.lighting

SIX COLOR BOOMERANG
Automatically clears the color in use when the next color is added. The color magazine will hold up to four colors simultaneously for versatile color mixing.

AUTO RETURN BUTTON

COLOR FAN
Quietly cools color media for extended life

GLASS FRONT LENS
Lightweight and unbreakable

FRONT LENS CONTROL
Maintenance-free guide bearings for smooth focusing

REAR LENS
Coated for greater light output

HOURLY METER

DOWSER, IRIS, CLIPPER
All move in one direction. Iris and clipper in same focal plane. Precision in alloy iris.

RELAY LENSES
Coated for greater light output

LAMP
Osram HTI 400 watt. Arc tube is axially mounted in its own elliptical dichroic reflector. Color temperature 5600°K, 250 hours.

LAMP FAN
Cools lamp and keeps rear housing temperature low for comfortable operation

BALLAST
Solid-State ballast contained in lamp housing simplifies set-up and transport

LAMP ADJUSTMENT PLATE
Allows full lamp alignment

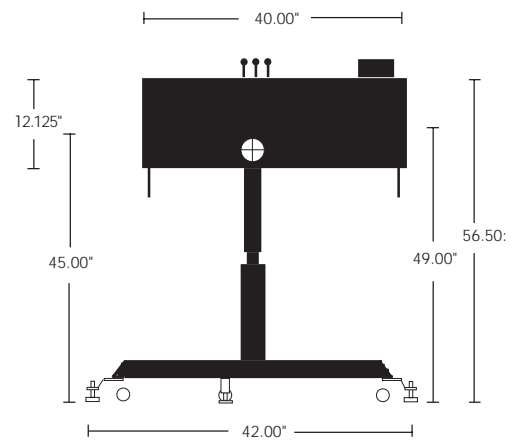
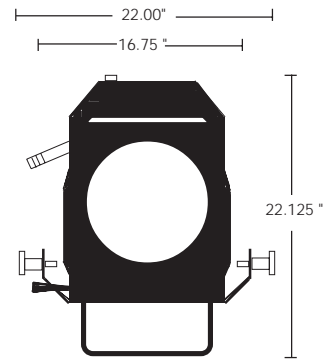

Series II Short Throw Optical System Performance At Various Distances

Throw In Feet	Spot			Flood		
	Min Diam	Max Diam	Footcandles	Min Diam	Max Diam	Footcandles
20	9"	30"	2550	15"	7' 6"	595
60	2"	7' 8"	283	45"	22'	66
100	3' 6"	12' 6"	102	6' 4"	38'	23
140	5' 2"	18"	51	8' 9"	53'	12
180	6' 8"	22'	31	11' 5"	65'	7
200	7' 6"	25'	26	12' 6"	71'	6

SPECIFICATIONS

Head Length	40"
Overall Head Height	22.125"
Overall Height w/Base	56.5"
Height of Pivot Point	45"
Floor to Beam Center	49"
Base Width	42"
Front Clearance Radius for:	
Vertical Movement	26"
Horizontal Movement	24"
Rear Clearance Radius for:	
Vertical Movement	23"
Horizontal Movement	22"
Maximum Height at Rear with Downward Tilt	68"
Maximum Height at Front with Upward Tilt	70.5"
Maximum Downward Tilt From Horizontal	70°
Maximum Upward Tilt From Horizontal	60°
Horizontal Sweep	360°
Lamp	HTI 400 Watt
Power Requirement	8 A 120 VAC

Total Operating Weight Including Base **128 lbs**